

THE POWER BEHIND THE PROCESS

PROCESSPOWER™ UPS System



**Industrial PWM
Uninterruptible
Power Supply
Systems**

**Single Phase
10-125kVA**

The purpose of our business is to provide continuity of electrical power to keep businesses in business.



PROCESSPOWER UPS System

The ProcessPower UPS from Solidstate Controls is a true, on-line, double-conversion uninterruptible power supply system that provides clean, regulated, continuous power for critical AC loads. Designed specifically for process control and other industrial applications, the ProcessPower UPS utilizes state-of-the-art PWM technology incorporating high power IGBT semiconductors. The ProcessPower UPS includes advanced communications capability, along with a high resolution LCD graphics display interface panel for complete system status, including alarms, and voltage and current parameters.

UPS Monitoring With LCD Panel

The ProcessPower UPS features an alphanumeric LCD panel with graphics display for all system functions. The following parameters are displayed:

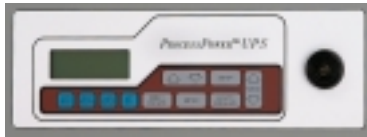

System Operational Values For:

- Battery Current
- Battery Voltage
- Battery Capacity Remaining
- Rectifier Output Current
- AC Output Voltage
- AC Output Current
- AC Output Frequency

Alarm Status:

- Rectifier/charger failure
- Low battery voltage
- High battery voltage
- Inverter failure
- Inverter over-temperature
- Static switch over-temperature
- Inverter protection
- Retransfer inhibited
- Bypass out of frequency
- Battery charger over-temperature
- Bypass failure
- Battery supplying load

System Status Indicators:

- Charger float/equalize status
- Inverter and bypass in sync
- Equalize timer with on-screen countdown
- Inverter status
- Bypass source status
- Static switch position
- Manual bypass switch position

A keypad is used to operate the panel and permit selection of functions. Alarm panel operation is also possible if the primary fails.

Communications Interface

All ProcessPower UPS models include an RS232 with Windows™ based communications software that permits the user to monitor the UPS from a remote terminal and to see the information presented on the LCD panel mounted on the front of the UPS.

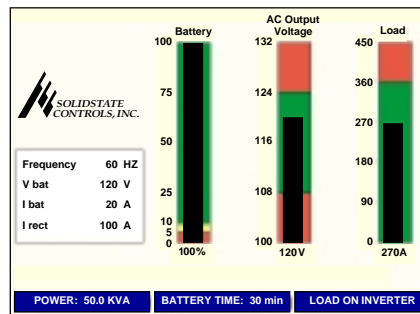

Typical Bar Chart Display Via RS232

Other Standard Features Include:

- AC Input Breaker
- Battery Input Breaker
- Dry Contact for UPS Summary
- Dry Contact for Bypass Supplying Load Alarm
- Audible Alarm with reset
- Input and Output Isolation Transformers
- Battery Test Pushbutton
- Inverter Reset Pushbutton
- Static Switch Retransfer Inhibit Reset
- Full Control of the Static Switch via Fully Rated SCRs on Inverter and Bypass Legs
- Top and Bottom Cable Entry
- Separate Inputs for Main AC and Bypass Sources

Optional Features Include:

- Bypass Input Circuit Breaker
- System Output AC Circuit Breaker
- Inverter Output Breaker
- Cabinet Drip Shield
- Space Heater With Thermostat
- RS485 Communications Interface
- DC Ground Detection
- Remote 3-Position Manual Bypass Switch
- <10% Input Current Harmonic Distortion Filtering
- Rectifier Configuration with Blocking Diode
- Fungus/Moisture Proofing

It's What's Inside That Makes The Difference.

Solidstate Controls' industrial PWM UPS systems provide 100% front accessibility for the ultimate in ease of operation and maintenance. Our custom capabilities enable us to design magnetics to meet a wide variety of voltage and frequency configurations.

Wire raceway for easier cable connections

Cooling fans mounted directly on heat sinks provide more than adequate ventilation, limiting need for top-mounted fans on most designs

Fail-safe static transfer switch design

PC boards mounted on swing-out panels allow easy maintenance

Front accessible thermal magnetic breakers

Front accessible manual bypass switch

Easily accessible power connections made to copper bus bars — top and bottom cable entry

Custom-designed magnetics — 20 year design life

100% front access for ease of maintenance and operation

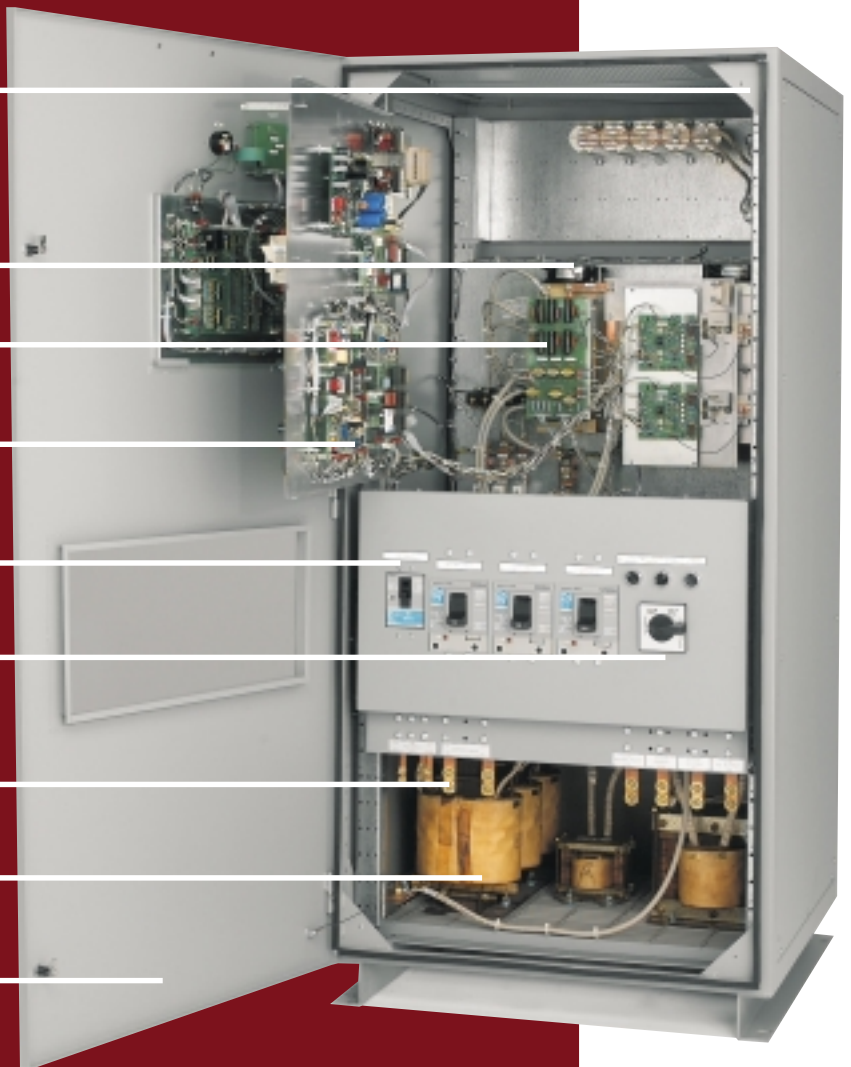

Base Product

Model	kVA	kW	DC Bus Voltage	3Ø AC Input/Frequency ¹				AC Input Breaker				Inverter DC-AC % Efficiency	UPS Cabinet Style	Heat Loss Watts	Inverter DC Input Amperes	Batt. Input Breaker Ampacity	Weight ² Lbs.(Kg)
				AC Amperes/Phase				Ampacity									
				380/50	480/60	600/60	208/60	380/50	480/60	600/60	208/60						
PPR010-*	10	8	120	26	20	16	47	35	30	20	60	87	GTD45M	1995	68	125	1100 (499)
PPR015-*	15	12	120	38	30	24	70	50	40	30	90	87	GTD45M	2993	102	175	1300 (590)
PPR020-*	20	16	120	51	40	32	92	70	50	40	125	87	GTD45M	3775	136	225	1500 (680)
PPR030-*	30	24	240	75	60	48	138	100	80	60	175	89	GTD45M	4996	100	175	1950 (884)
PPR040-*	40	32	240	99	79	63	182	125	100	80	250	89	GTD45M	6250	133	225	2050 (930)
PPR050-*	50	40	360	119	94	76	218	150	125	100	300	92	GTD53	7259	107	175	2150 (975)
PPR060-*	60	48	360	143	113	91	262	200	150	125	350	92	GTD53	8711	129	225	2550 (1157)
PPR080-*	80	64	360	191	151	121	349	250	200	150	450	92	GTD53	11614	172	300	3050 (1383)
PPR100-*	100	80	360	239	189	151	436	300	250	200	600	92	GTD60M	14518	215	350	3700 (1678)
PPR125-*	125	100	360	298	236	189	545	400	300	250	700	92	GTD60M	18147	268	450	4440 (1995)

120 VDC Option

Model	kVA	kW	DC Bus Voltage	3Ø AC Input/Frequency ¹				AC Input Breaker				Inverter DC-AC % Efficiency	UPS Cabinet Style	Heat Loss Watts	Inverter DC Input Amperes	Batt. Input Breaker Ampacity	Weight ² Lbs.(Kg)
				AC Amperes/Phase				Ampacity									
				380/50	480/60	600/60	208/60	380/50	480/60	600/60	208/60						
PPR010-*	10	8	120	26	20	16	47	35	30	20	60	87	GTD45M	1995	68	125	1100 (499)
PPR015-*	15	12	120	38	30	24	70	50	40	30	90	87	GTD45M	2993	102	175	1300 (590)
PPR020-*	20	16	120	51	40	32	92	70	50	40	125	87	GTD45M	3775	136	225	1500 (680)
PPR030-*	30	24	120	76	57	45	131	100	80	60	175	87	GTD53	5663	204	350	1950 (884)
PPR040-*	40	32	120	101	76	60	174	150	100	80	250	87	GTD53	7550	273	450	2050 (930)
PPR050-*	50	40	120	126	100	80	231	175	125	100	300	87	GTD60M	9438	341	600	2500 (1134)
PPR060-*	60	48	120	151	120	96	277	200	150	125	350	87	GTD60M	11325	409	700	2950 (1338)

240 VDC Option

Model	kVA	kW	DC Bus Voltage	3Ø AC Input/Frequency ¹				AC Input Breaker				Inverter DC-AC % Efficiency	UPS Cabinet Style	Heat Loss Watts	Inverter DC Input Amperes	Batt. Input Breaker Ampacity	Weight ² Lbs.(Kg)
				AC Amperes/Phase				Ampacity									
				380/50	480/60	600/60	208/60	380/50	480/60	600/60	208/60						
PPR010-*	10	8	240	25	20	16	46	40	25	20	60	89	GTD45M	1665	33	60	1100 (499)
PPR015-*	15	12	240	38	30	24	69	50	40	30	90	89	GTD45M	2498	50	80	1300 (590)
PPR020-*	20	16	240	50	40	32	91	70	50	40	125	89	GTD45M	3125	67	110	1500 (680)
PPR030-*	30	24	240	75	60	48	138	100	80	60	175	89	GTD45M	4996	100	175	1950 (884)
PPR040-*	40	32	240	99	79	63	182	125	100	80	250	89	GTD45M	6250	133	225	2050 (930)
PPR050-*	50	40	240	124	98	79	227	175	125	100	300	89	GTD53	7813	167	300	2150 (975)
PPR060-*	60	48	240	149	118	94	272	200	150	125	350	89	GTD60M	9375	200	350	2550 (1157)
PPR080-*	80	64	240	198	158	126	364	250	200	175	500	89	GTD60M	12500	266	450	3400 (1542)
PPR100-*	100	80	240	248	196	158	454	350	250	200	600	89	GTD53*	15626	334	600	4400 (1995)
PPR125-*	125	100	240	310	245	198	568	400	300	250	700	89	GTD53*	19532	418	700	5400 (2449)

* Two GTD53 cabinets required.

110 VDC Option

Model	kVA	kW	DC Bus Voltage	3Ø AC Input/Frequency ¹				AC Input Breaker				Inverter DC-AC % Efficiency	UPS Cabinet Style	Heat Loss Watts	Inverter DC Input Amperes	Batt. Input Breaker Ampacity	Weight ² Lbs.(Kg)
				AC Amperes/Phase				Ampacity									
				380/50	480/60	600/60	208/60	380/50	480/60	600/60	208/60						
PPR010-*	10	8	110	26	19	15	44	40	25	20	60	87	GTD45M	1995	74	125	1100 (499)
PPR015-*	15	12	110	38	28	23	65	50	40	30	90	87	GTD45M	2993	111	200	1300 (590)
PPR020-*	20	16	110	51	38	30	87	70	50	40	125	87	GTD45M	3775	148	250	1500 (680)
PPR030-*	30	24	110	75	57	45	131	100	80	60	175	87	GTD53	5663	222	400	1950 (884)
PPR040-*	40	32	110	99	76	60	174	125	100	80	250	87	GTD53	7550	297	500	2050 (930)
PPR050-*	50	40	110	123	99	79	229	150	125	100	300	87	GTD60M	9438	371	600	2500 (1134)
PPR060-*	60	48	110	151	119	95	275	200	150	125	350	87	GTD60M	11325	445	725	2950 (1338)

220 VDC Option

Model	kVA	kW	DC Bus Voltage	3Ø AC Input/Frequency ¹				AC Input Breaker				Inverter DC-AC % Efficiency	UPS Cabinet Style	Heat Loss Watts	Inverter DC Input Amperes	Batt. Input Breaker Ampacity	Weight ² Lbs.(Kg)
				AC Amperes/Phase				Ampacity									
				380/50	480/60	600/60	208/60	380/50	480/60	600/60	208/60						
PPR010-*	10	8	220	25	20	16	46	30	25	20	60	89	GTD45M	1665	36	60	1100 (499)
PPR015-*	15	12	220	38	30	24	69	45	40	30	90	89	GTD45M	2498	55	90	1300 (590)
PPR020-*	20	16	220	50	40	32	92	60	50	40	125	89	GTD45M	3125	73	125	1500 (680)
PPR030-*	30	24	220	75	60	48	138	100	80	60	175	89	GTD45M	4996	109	175	1950 (884)
PPR040-*	40	32	220	100	80	64	182	125	100	80	250	89	GTD45M	6250	145	250	2050 (930)
PPR050-*	50	40	220	126	99	79	229	150	125	100	300	89	GTD53	7813	182	300	2150 (975)
PPR060-*	60	48	220	151	119	95	275	200	150	125	350	89	GTD60M	9375	218	350	2550 (1157)
PPR080-*	80	64	220	202	159	126	369	250	200	175	500	89	GTD60M	12500	290	500	3400 (1542)
PPR100-*	100	80	220	252	199	159	461	300	250	200	600	89	GTD53*	15626	364	600	4400 (1995)
PPR125-*	125	100	220	315	249	198	576	400	300	250	750	89	GTD53*	19532	456	750	5400 (2449)

* Two GTD53 cabinets required.

¹ At nominal line & current limit.

² Weight shown is for 60 Hz units; add 7% for 50 Hz.

* A complete model number includes the AC input voltage, DC bus (link) voltage, AC output voltage and system frequency. To "build" a model number, use the "code" in the matrix shown below. Model Number: PPR010-XX-YY-ZZ-AA where, XX=AC Input Voltage, YY=DC Bus Voltage, ZZ=AC Output Voltage, AA=System Frequency.

For example: a 10kVA UPS, with 480VAC, 60Hz input voltage; 120VDC bus, 120 VAC output voltage is model number PPR010-48-12-12-60.

AC Input Volts	Code	DC Bus Volts	Code	AC Output Volts	Code	Freq	Code
380	38	360	36	120	12	60	60
480	48	120	12	220	22	50	50
600	60	240	24				
208	20	110	11				
415	41	220	22				

If a voltage code is not listed, place a 'C' after the base model number; example: PPR010C.

Cabinet Style	Cabinet Dimensions		
	H	W	D
GTD45M	70.9 (1800)	33.5 (850)	34.4 (875)
GTD53	70.9 (1800)	51.2 (1300)	34.4 (875)
GTD60M	70.9 (1800)	84.7 (1389)	34.4 (875)

Note: The GTD60M cabinet style is made up of one GTD45M cabinet and one GTD53 cabinet.

Battery Charger/Rectifier

AC Input

Voltages: 600, 480, 240, 208, 415, 380, and 220VAC, 3-phase, 3-wire

Range: +10, -15%

Frequency: 50 or 60Hz $\pm 5\%$

DC Output

DC Bus Voltage: 110, 120, 220, 240, 360 — Custom configurations available, consult factory.

Regulation: $\pm 1\%$

Ripple Voltage: <2% with battery connected

Capacity: Sized to recharge a one-hour battery to 95% of its rated capacity within 8 hours, while simultaneously supplying power to a fully loaded inverter

Inverter

DC Input

Voltage Range: 105-140VDC for 60 cell systems
 (Values given for Lead-Calcium batteries. Consult factory for Ni-Cad)
 210-280VDC for 120 cell systems
 315-419VDC for 180 cell systems
 96-128VDC for 55 cell systems
 192-256VDC for 110 cell systems

AC Output

Capacity (Range): 10-125kVA single phase

Voltages: 120, 220VAC single phase

Voltage Regulation: $\pm 1\%$

Frequency: 50 or 60Hz

Frequency Regulation: $\pm 0.1\%$

Sync Range: $\pm 0.5\text{Hz}$

Load Power Factor: 0.8

Total Harmonic Distortion: <3% with linear load
 <5% with non-linear load

Overload Capacity: 105% continuous
 125% for 10 minutes
 150% for 10 seconds

Crest Factor: 3:1 at full load

Dynamic Voltage Regulation: 0-100%, $\pm 5\%$ (peak)

Dynamic Voltage Response: Return to 1% within 50 milliseconds

Output Voltage Adjustment: $\pm 5\%$

Environmental

Ambient Temperature: 0°C to 40°C (50°C available)

Relative Humidity: 0-95% non-condensing

Operating Altitude: 0 to 10,000 feet (3,300 meters)

Audible Noise: <60dB(A) at 1 meter

Cable Entry

Top or bottom entry standard

Controls

(Pushbutton & Indicator)

Bypass to Load Pushbutton

Float Voltage Pushbutton

Equalize Voltage Pushbutton

Enable Inverter (on/off switch)

Auto Retransfer (on/off switch)

Static Switch

Configuration:

SCR control on inverter and bypass inputs

Transfer Time:

Make-before-break (normal conditions)

Transfer Criteria:

Output waveform distortion

(from inverter to bypass)

High inverter output voltage

Low inverter output voltage

Manual Initiation

Retransfer Criteria:

Inverter in sync with bypass supply

(from bypass to inverter)

Output waveform within tolerance

Inverter output voltage within

tolerance ($\pm 5\%$)

Bypass voltage within tolerance ($\pm 10\%$)

Commutation Type:

Forced via reed relay

Overload Capacity:

150% for 10 minutes

200% for 1 minute

400% for 1 second

1000% for 50 milliseconds

Manual Bypass Switch (Electro-Mechanical)

Transfer Criteria:

Manual operation; inverter and bypass supply must be in sync

Transfer Time:

Zero; make-before-break

Positions:

Four position switch:

1 - Normal, load connected to inverter

2 - Static switch on bypass

3 - Load on bypass

4 - Isolated bypass

Mean Time Between Failure (MTBF)

MTBF:

>140,000 Hours

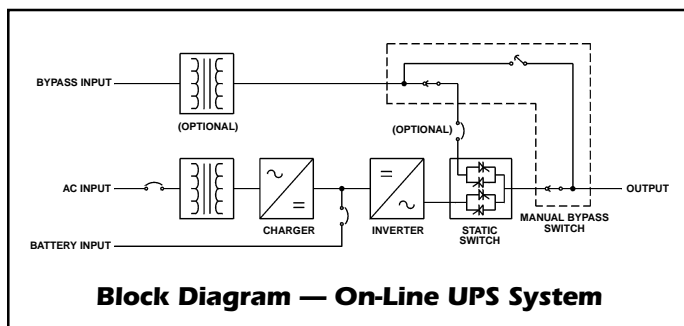

World Headquarters:

875 Dearborn Drive, Columbus, OH 43085

Toll-Free 800-635-7300 (U.S. & Canada) ■ +1-614-846-7500 ■ Fax: +1-614-885-3990

Asia Pacific Headquarters:

Chinachem Hollywood Center, Suite 401-2, 1-13 Hollywood Road, Central Hong Kong

Phone: +852-2526-1967/1970 ■ Fax: +852-2526-0225

South American Headquarters:

Av. Belgrano 553 1° 'C' (1092) Buenos Aires, Argentina

Phone: +(54-11) 4342-1138 ■ Fax: +(54-11) 4342-6220

Specifications subject to change without notice.



www.solidstatecontrolsinc.com



A member of The Marmon Group of companies

PPR001 (2/01) 3M