

# PROCESSPOWER<sup>®</sup>

## UPS System

The Digital PROCESSPOWER (DPP) UPS from Solidstate Controls is a true on-line, double conversion Uninterruptible Power Supply system that provides continuous clean, regulated power for critical AC loads. Designed specifically for process control and industrial applications, the DPP systems utilize state of the art PWM technology, incorporating high power IGBT semiconductors, and digital control for enhanced communications, monitoring, control and diagnostics capabilities. Also essential to the DPP design is the use of fiber optic cables for control and communications; allowing for better isolation and faster, more accurate signals between processors. The DPP designs also include an LCD panel and user-friendly touch screen display for the ultimate in User control.



**Industrial PWM  
Uninterruptible  
Power Supply  
Systems**

**Three Phase  
10-100 kVA**

*The Purpose of our business is to provide continuity of electrical power to keep businesses in business.*



[www.solidstatecontrolsinc.com](http://www.solidstatecontrolsinc.com)

**World Headquarters** (an ISO Certified Quality Management System Facility)  
875 Dearborn Drive Columbus, Ohio 43085  
Toll-Free 800-635-7300 (U.S. & Canada) \* +1-614-846-7500-Fax +1-614-885-3990  
**Asia Pacific Headquarters**  
Golden Sun Ctr-Flats F-G 12<sup>th</sup> Floor- 59-67 Bonham Strand West  
Sheung Wan Hong Kong  
Phone +852-2526-1967/1970 Fax +852-2526-0225  
**Latin American/South American Headquarters**  
Olive 1954 2000 Rosario, Argentina  
Phone +(54-34) 341-455-3332 Fax +(54-34) 341-454-0142

CERTIFIED  
ISO 9001



A member of The Marmon Group of companies

PPR Digital 12/2002-So Prnt-2000 pcs

## General Specifications-Performance Features

### PROCESSPOWER UPS System

### LCD and Touch Screen User Interface Panel

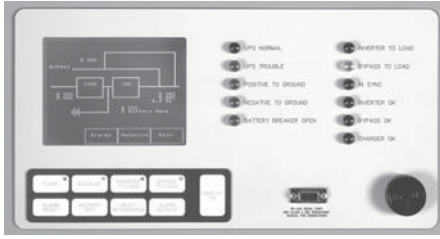

Shown with optional indicator lights

#### Keypad Controls and Switches:

- Float/Equalize Initialization w/Light
- Battery Test Initialization
- Inverter to Load w/Light
- Bypass to Load w/Light
- Static Switch Reset Retransfer
- Latching Alarm Reset
- Audible Alarm Silence
- Display On
- Inverter Enable (On/Off) Switch

#### Standard Mimic Screen (LCD Panel) Indicators:

- Equalize Time Remaining
- Charger Status (OK/Fail)
- Float/Equalize Status
- Inverter Status (OK/Fail)
- Synchronism Status (In/Out of sync)
- Static Switch Position (Inverter or Bypass)
- Manual Bypass Position (Inverter or Bypass)
- Bypass Status (OK/Fail)

#### Standard LED Indicators for:

- UPS Normal
- UPS Trouble

## General Specifications-Standard Features

#### • Circuit Breakers:

- AC Input (14kAIC)
- Battery Input (10kAIC, min.)
- Bypass Input (14kAIC)

#### • Metering (Displayed on Mimic Screen):

- DC Bus Voltage
- DC Bus Current ( $\pm$ )
- AC Output Voltage
- AC Output Current
- AC Output Frequency
- Rectifier Output Current

#### • System Measurements (Displayed on Mimic Screen):

- Total Number of Battery Discharges
- Total Operational Time on Batteries
- Average Time on Battery per Discharge
- Historical Min/Max Battery Voltage
- Recent Min/Max Battery Voltage
- Total Operation Time on UPS
- Total Operation Time on Bypass
- Total Operation Time on Inverter

#### • Alarms (Displayed on LCD Alarm Panel):

- Fan Failure
- Charger Failure

#### • Alarms (Displayed on LCD Alarm Panel) cont

- Low DC Voltage
- ST/SW Retransfer Blocked
- Battery Discharging
- Inverter Bridge Over Temperature
- IGBT Desaturation
- Overload Shutdown
- Bypass Supplying Load
- ST/SW Bridge Over Temperature
- ST/SW SCR Failure
- Bypass Failure
- Inverter Failure

#### • System Diagnostics (Displayed on LCD Alarm Panel):

- Loss of System Communication(s)
- Power Supply Failure(s)

#### • Relay Controls:

- The following alarms also include 1 set of normally open and normally closed relay contacts rated for 120 VAC @3 amps:
  - UPS Trouble (Summary)
  - Bypass Supplying Load
  - UPS Communications Failure (Summary)

## General Specifications-Optional Features

#### • Metering and System Measurements:

- AC Input Power (Voltage and Current)
- Inverter Output Voltage
- Bypass Input Voltage
- Output Power (kVA, KW, Power Factor)
- Bypass Input Frequency
- % Inverter Loading

#### • Circuit Breakers

- 65 KAIC AC Input and Bypass Input
- Inverter Output (non-Automatic)
- A/C Output

#### • Alarms

- Charger Overload
- Battery Failure
- High DC Disconnect
- Low DC Disconnect

#### • Alarms-cont.

- Pos/Neg to Ground
- High/Low Bypass Source Voltage
- High/Low AC Output Voltage
- AC Input Failure
- AC Output Overload
- High/Low Inverter Output Voltage
- Out-Of-Sync
- Inverter Fuse Blown
- Inverter Off Frequency
- Bypass Off Frequency
- Static Switch Fuse Blown
- Battery Breaker Open
- Battery Near Exhaustion
- No Output
- Rectifier/Charger Fuse Blown
- Low AC Input Voltage

#### • Alarms-cont.

- High DC Voltage
- Rectifier/Charger Failure
- MBS to Bypass
- AC Input CB Open
- Bypass Input CB Open
- AC Output CB Open

#### • Misc.

- External MBS
- Rectified Configuration
- Cascade Redundant Configuration
- 10% Reflected Harmonics (Rectifier Input)
- Additional LED Indicators
- Additional Relay Contacts
- Latching Alarms
- Lamp test

## General Specifications-Performance Features

### Battery Charger/Rectifier

· AC Input	
Nominal Voltage*	208,380,415, 480: 3-Phase/3-Wire
Input Range	± 10%
Frequency	50 or 60 Hz ± 5%
· DC Output	
DC Bus Voltage(s)	110, 120, 220, 240 and 360 VDC
Regulation	± 1%
Ripple Voltage	<2% with battery connected
Capacity	Sized to recharge a thirty (30) min. battery to 95% of its rated capacity within eight (8) hours, while simultaneously supplying power to a fully loaded inverter
Float/Equalize	± 5% Adjustability

### Inverter

· DC Input	
Nominal Voltage	110V/55 (96-128VDC)
Range/ # of Cells	120V/60 (105-140VDC)
(Lead Calcium Type)	220V/110 (192-256VDC)
	240V/120 (210-280VDC)
	360V/180 (315-419VDC)
Battery End Voltage	1.75 end volts per cell
(Lead Calcium Type)	
· AC Output	
Inverter/UPS Ratings	10-100 kVA
Power Factor	0.8 – 1.0
AC Output voltage*	120/208; 220/380; 277/480, 3-phase, 4-wire
Regulation	± 1%
Voltage Adjustment	± 5%
Frequency	50 or 60 Hz; ± 0.1%
Crest Factor	3:1
Total Harmonic Distortion (THD)	100% linear load <3% 100% non-linear load <5%
Transient Response	± 5% (0-100% load)
Recovery Time	< 50 msec to ± 1%
Overload Capacity	100% - continuous 125% - 10 minutes 150% - 1 minute

\*Custom Input and Output Voltages available-consult factory

## Reliability for Critical Industrial Applications



**Oil Platforms**



**Process Control**



**Petrochemical**

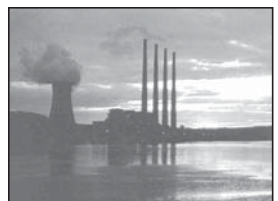

**Power Generation**

### Static Switch

Bypass Voltage	120/208, 220/380, 277/480 3-Phase 4 Wire
Switch Type	Inversely paired set of SCRs (one set per leg)
Failure Mode	Automatically fails to Bypass
Transfer Time	Make Before Break:
Sync Capture Range	0.5% to 1.5%
Slew Rate	1Hz/sec to 10Hz/sec (adjustable)
Overload Capability	125% continuous; 150% for 10 minutes; 200% for 1 minute; 1000% for 1 cycle

### Manual Bypass Switch

Voltage	120/208, 220/380, 277/480 3-Phase 4 Wire
Mounting Positions	Inside UPS/Inverter Enclosure Two
Construction	Electro-Mechanical Rotary Type
Transfer Time	Make Before Break
Overload Capacity	125% continuous; 150% for 10 minutes; 200% for 1 minute; 1000% for 1 cycle

### Environmental

Ambient Temperature	-5 to 40°C (23 to 104°F)
Relative Humidity	0-95% non-condensing
Operating Altitude	0-3300 meters (10,000 feet)
Audible Noise	65dB(A) @ 1 meter
Cooling	Aided Convection or Forced Air, depending on kVA rating and design

### Cable Entry

Top or Bottom Entry Standard

### Mean Time Between Failure (MTBF)

> 140,000 Hours

### Cabinet Rating

Nema 1 (IP-20) (other enclosure ratings available-consult factory)

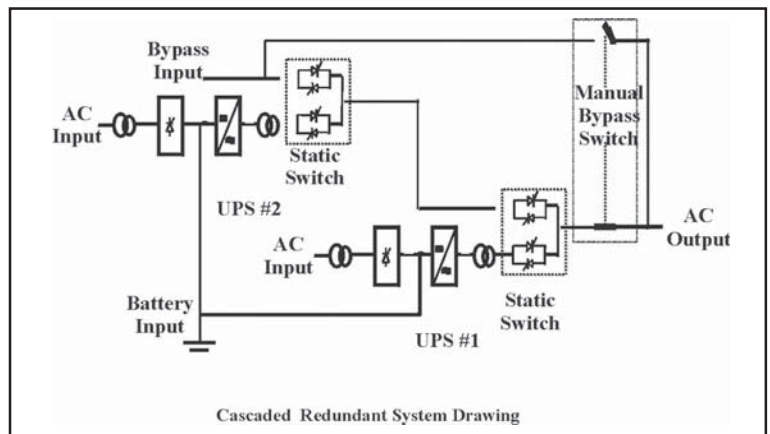
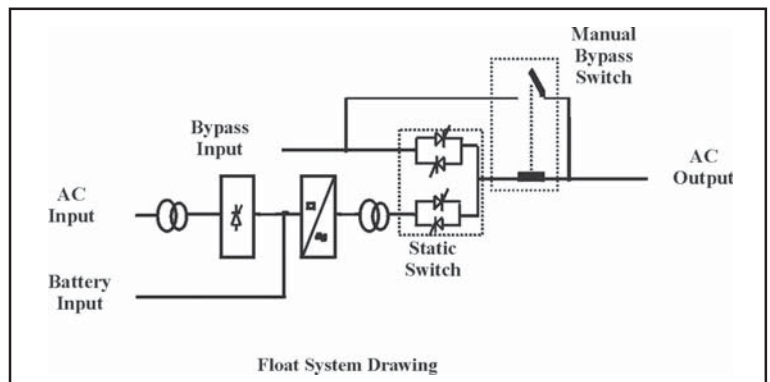

## 0.8 Output Power Factor

120 VDC (60 Lead Calcium Battery Cell)															
Model	Rated Output Power		Efficiency		3PH AC Input/Freq AC Amperes per Phase *			DC Current*	3PH AC Output Amps Per Phase*			UPS Cabinet Style	Weight		Heat Loss (Watts)
	kVA	kW	AC-DC	DC-AC	480/60	208/60	380/50	1.75 VPC	480	208	380		Lbs.	Kg.	
3DPP010-*	10	8	92%	87%	21	48	26	88	12	28	15	GTD1X	1100	499	1995
3DPP015-*	15	12	92%	87%	30	70	39	131	18	42	23	GTD1X	1300	590	2993
3DPP020-*	20	16	93%	87%	40	92	50	175	24	56	30	GTD1X	1500	680	3775
3DPP030-*	30	24	93%	87%	59	136	75	263	36	83	46	GTD2X	1950	885	5663
3DPP040-*	40	32	93%	87%	78	181	99	350	48	111	61	GTD2X	2050	930	7550
3DPP050-*	50	40	93%	87%	99	228	125	438	60	139	76	GTD3X	2150	975	9438

240 VDC (120 Lead Calcium Battery Cell)															
Model	Rated Output Power		Efficiency		3PH AC Input/Freq AC Amperes per Phase *			DC Current*	3PH AC Output Amps Per Phase			UPS Cabinet Style	Weight		Heat Loss (Watts)
	kVA	kW	AC-DC	DC-AC	480/60	208/60	380/50	1.75 VPC	480	208	380		Lbs.	Kg.	
3DPP030-*	30	24	93%	89%	58	134	73	128	36	83	46	GTD1X	1950	885	4996
3DPP040-*	40	32	94%	89%	76	176	97	171	48	111	61	GTD2X	2050	930	6250
3DPP050-*	50	40	94%	89%	96	220	121	214	60	139	76	GTD2X	2150	975	7813
3DPP060-*	60	48	94%	89%	119	276	151	257	72	167	91	GTD3X	2550	1157	9375
3DPP080-*	80	64	94%	89%	153	353	193	342	96	222	122	GTD3X	3400	1542	12500
3DPP100-*	100	80	94%	89%	191	441	241	428	120	278	152	GTD4X	4400	1996	15625

## 1.0 Output Power Factor

120 VDC (60 Lead Calcium Battery Cell)															
Model	Rated Output Power		Efficiency		3PH AC Input/Freq AC Amperes per Phase *			DC Current*	3PH AC Output Amps Per Phase*			UPS Cabinet Style	Weight		Heat Loss (Watts)
	kVA	kW	AC-DC	DC-AC	480/60	208/60	380/50	1.75 VPC	480	208	380		Lbs.	Kg.	
3DPP010-*	10	10	92%	87%	30	70	39	109	12	28	15	GTD1X	1300	590	2494
3DPP015-*	15	15	92%	87%	40	93	51	164	18	42	23	GTD1X	1500	680	3539
3DPP020-*	20	20	93%	87%	60	139	76	219	24	56	30	GTD2X	1950	885	4719
3DPP030-*	30	30	93%	87%	81	187	102	328	36	83	46	GTD2X	2050	930	7078
3DPP040-*	40	40	93%	87%	99	228	125	438	48	111	61	GTD3X	2150	975	9438

240 VDC (120 Lead Calcium Battery Cell)															
Model	Rated Output Power		Efficiency		3PH AC Input/Freq AC Amperes per Phase *			DC Current*	3PH AC Output Amps Per Phase*			UPS Cabinet Style	Weight		Heat Loss (Watts)
	kVA	kW	AC-DC	DC-AC	480/60	208/60	380/50	1.75 VPC	480	208	380		Lbs.	Kg.	
3DPP030-*	30	30	93%	89%	77	178	98	161	36	83	46	GTD2X	2050	930	5859
3DPP040-*	40	40	94%	89%	96	220	121	214	48	111	61	GTD2X	2150	975	7813
3DPP050-*	50	50	94%	89%	119	276	151	268	60	139	76	GTD3X	2550	1157	9766
3DPP060-*	60	60	94%	89%	153	353	193	321	72	167	91	GTD3X	3400	1542	11719
3DPP080-*	80	80	94%	89%	191	441	241	428	96	222	122	GTD4X	4400	1996	15625

\*Circuit Breakers are sized at a minimum of 125% of rated current

Specifications subject to change without notice

"DD"		"EE"		"FF"		"GG"		"HH"		"I"		"J"	
AC Input Volts	Code	DC Bus Volts	Code	AC Output Volts	Code	Freq.	Code	Output P.F.	Code	Charger Design	Code	UPS Config	Code
480	48	120	12	208	20	60	60	0.8	K	6-Pulse	S	Float	F
208	20	240	24	480	48	50	50	1.0	W	12-Pulse	T	Cascaded	C
380	38	360	36	380	38								

A complete model number includes the AC input voltage, DC bus (link) voltage, AC output voltage, system frequency, output power factor, and UPS configuration To "build" a model number, use the "code" in the matrix shown above, following the example format: 3DPP010-DD-EE-FF-GG-H-I-J; where DD=AC Input Voltage; EE=DC bus Voltage; FF=AC Output voltage; GG=system Frequency; H=Output Power Factor ('K' for 0.8; 'W' for 1.0); I=6 (S) or 12 (T) Pulse Charger design; J=UPS configuration ('F' for Float, 'C' for Cascaded Redundant.)

**For Example:** A 20 kVA with 480 volt input; 120 VDC bus voltage; 208 volt output; 60 Hz; 0.8 output power factor; 6=pulse charger; Float system would have the following model number:  
**3DPP020-48-12-20-60-K-S-F.**

For custom systems, and for units which do not have a configurable model number, insert a 'C' in the model number as follows: 3DPP020C.

Inches--Cabinet-Dimensions--mm										
Style	H	x	W	x	D	H	x	W	x	D
GTD1X	79	x	32	x	36	2007	x	813	x	914
GTD2X	79	x	54	x	36	2007	x	1372	x	914
GTD3X	79	x	86	x	36	2007	x	2184	x	914
GTD4X	79	x	108	x	36	2007	x	2743	x	914

Certain optional features and/or combinations may require larger cabinets. Contact factory